



# Instruction Manual

## 30 Pound Pressurized Cooling System Tester

Test pressure caps and locate leaks in automotive pressurized cooling systems. Tests caps and systems up to 30 pounds.

2009 Stant Corporation Inc.

# Table of Contents

Pressure Tester Operating Instructions .....	1
Testing the Pressure Cap .....	1
Testing the Cooling System.....	4
Tester Adapters .....	10
Repair Parts, Conversion Kits, Gaskets and Seals .....	17
Care of the Tester.....	19
Limited Warranty .....	Back Cover

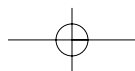
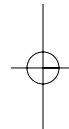
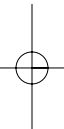

## PRESSURE TESTER OPERATING INSTRUCTIONS

### TESTING THE PRESSURE CAP

1. Carefully remove the cap from the vehicle. (**Warning: Do not perform any routine cooling system maintenance operations when the engine is hot. You may be burned by escaping hot coolant or steam.**) On lever design pressure release caps first lift lever to release cap pressure. Check the cap pressure (indicated in pounds, bars or millibars) as marked on the top of the cap. Compare it to the recommended pressure rating of the original equipment cap for the vehicle.

2. Determine which cap adapter is correct for the cap you are testing. See the tester adapter application data listed in the back of this book. Make sure all parts and seating surfaces of the cap and adapter are clean. On lever design pressure release caps, make sure the lever is in an up or open position.

3. On new caps, wet the rubber gasket in water. **NOTE:** Due to the newness of the gasket, it may be necessary to remove the pressure cap several times to get a proper sealing seat on the gasket. The gasket softens in actual car operation and will work perfectly.



*Tester head with pressure valve compressed.*

4. Apply the pressure cap to be tested as shown on the next page to one end of the cap adapter. Before attaching the adapter to the tester head, rotate the pressure valve release

handle on the top of the tester head clockwise until it is parallel to the tester head handle. In this position, the pressure valve is compressed, making it easier to install the adapter onto the tester head. Rotate the adapter until the locking ears contact the stops on the adapter cams. Lower the lever on pressure release type caps.

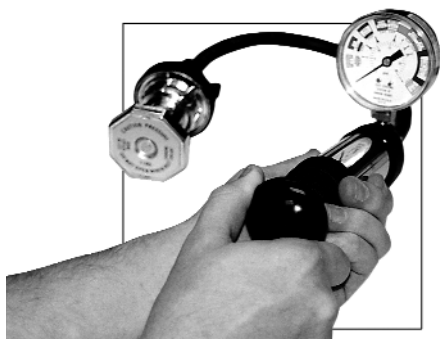

5. Rotate the pressure valve release handle on the tester head clockwise until the pressure valve in the tester head is released, sealing the tester head to the lower sealing seat of the adapter neck. You will feel the valve snap into place.

6. Hold the tester with gauge facing you as shown above.

7. Operate the pump and read the gauge when the needle reaches its highest point. NOTE: Remember that a cap that has been used on a radiator for some time will have a slight seat impression in the gasket; therefore, if the cap leaks, it should be removed and applied several times to the adapter to be sure that the leakage is not caused by the impression not seating properly. After the cap is reinstalled on the car, the continuous spring pressure will reseal the gasket properly in a short time.



*Tester head with pressure valve released.*

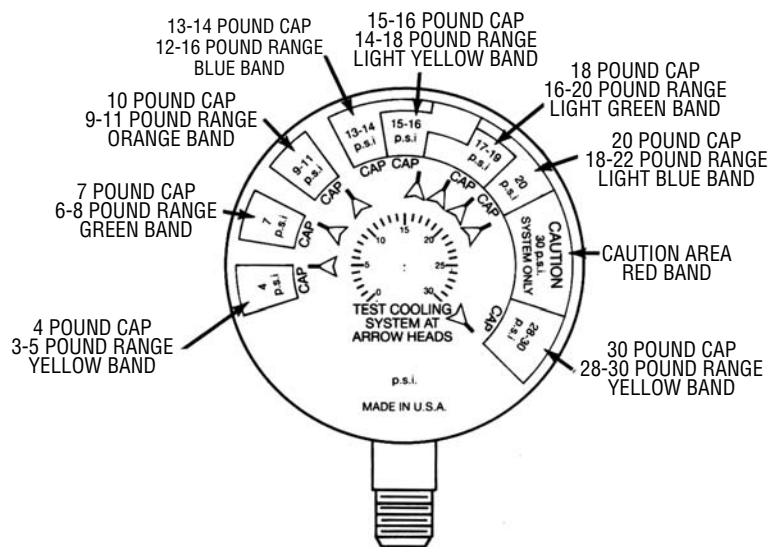

8. Stop pumping when the valve opens and read the gauge. The gauge hand must be within the proper color band for the pressure rating of the cap being tested when the pressure valve opens. The cap is satisfactory when the pressure holds steady or falls very slowly, but holds within the band for one minute. If the gauge hand falls comparatively fast (which indicates serious leakage), reject the pressure cap. Remove the cap from the tester and visually inspect the condition of the cap's pressure valve and upper and lower sealing gaskets. If the gaskets are hard, brittle or deteriorated, or if the cap fails to hold the proper pressure, replace it with a new cap in the same pressure range.

## TESTING THE COOLING SYSTEM

1. Carefully remove the radiator pressure cap from the filler neck. (Warning: Do not perform any routine cooling system maintenance operations when the engine is hot. You may be burned by escaping hot coolant or steam.)
2. Make sure coolant is at the recommended level in the radiator and overflow bottle.
3. Wipe out the inside of the filler neck. Examine the lower inside sealing seat of the filler neck for nicks, dirt and solder bumps.
4. Inspect the overflow tube and overflow bottle for dents, kinks, or internal obstructions. Run a wire through the tube to make sure it is clear. Pressure released by the pressure cap during the operation of the vehicle must pass through this tube. An obstructed tube or overflow bottle may cause the radiator or some portion of the cooling system to burst if pressure builds up excessively.



4

5. Inspect the cams on the outside of the filler neck. If cams are bent down or up, the seating of the pressure cap valve and the tester seal will be affected. Bent cams can be reformed if it is done carefully. DO NOT BREAK THE SOLDER JOINT BETWEEN THE NECK AND THE RADIATOR TOP TANK. Have the filler neck replaced by a reputable radiator repair service if it is in bad condition.

6. Determine if a radiator filler neck adapter is necessary for the application. See the tester adapter application data in the back of this book. Standard SAE 2-1/8" O.D., 3/4" deep filler necks as used on most U.S.-build cars will not require the use of an adapter. Drop the rubber spacer washer supplied with the tester in 1" deep 2-1/8" O.D. filler necks for testing. If an adapter is required, install it on the filler neck using the installation procedures outlined for it in the back of this book.

7. Before attaching the pressure tester head to the radiator or adapter, rotate the pressure valve release handle on the top of the tester head clockwise until it is parallel to the tester head handle. In this position the pressure valve is compressed, making it easier to install the tester head onto the adapter. Rotate the tester head until the locking ears contact the stops on the adapter cams. Rotate the pressure valve release handle on the tester head clockwise until the pressure valve in the tester head is released, sealing the tester head to the lower sealing seat of the adapter neck. You will feel the valve snap into place.

8. Check published specifications (such as the vehicle owners manual) to determine the proper pressure of the system being tested.



Tester head with pressure valve compressed.

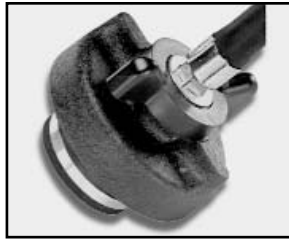

Tester head with pressure valve released.

9. Operate the pump until the indicator hand on the gauge reaches the arrow just beyond the end of the color band for the recommended pressure for the vehicle.

4 POUND SYSTEM should be pumped up the line indicated by the YELLOW ARROWHEAD. DO NOT EXCEED THIS POINT.

7 POUND SYSTEM should be pumped up to the line indicated by the GREEN ARROWHEAD. DO NOT EXCEED THIS POINT.

13-14 POUND SYSTEM should be pumped up to the line indicated by the BLUE ARROWHEAD. DO NOT EXCEED THIS POINT.

15-16 POUND SYSTEM should be pumped up the line indicated by the LIGHT YELLOW ARROWHEAD. DO NOT EXCEED THIS POINT.

18 POUND SYSTEM should be pumped up to the line indicated by the LIGHT GREEN ARROWHEAD. DO NOT EXCEED THIS POINT.

20 POUND SYSTEM should be pumped up the line indicated by the LIGHT BLUE ARROWHEAD. DO NOT EXCEED THIS POINT.

30 POUND SYSTEM should be pumped up to the line indicated by the YELLOW ARROWHEAD (the yellow arrowhead on the right side of the gauge). DO NOT EXCEED THIS POINT.

NEVER EXCEED THE ARROW POINTS OF THE RECOMMENDED PRESSURE OF THE SYSTEM BEING TESTED as it is not necessary to go beyond the arrow to determine if a leak exists. Excessive pressure can rupture the radiator, hoses, etc. NEVER PRESSURIZE BEYOND THE 30 POUND LEVEL FOR ANY COOLING SYSTEM as serious damage to it may occur. AFTER PUMPING THE PROPER AMOUNT OF PRESSURE INTO THE SYSTEM OBSERVE THE GAUGE.

Hand holds steady

If the hand holds steady for two minutes, there are no serious leaks in the system. Nevertheless, examine all points for seepage or slight leakage with a flashlight.

Hand drops slowly

Indicates the presence of small leaks or seepage. Check radiator, hose gaskets, and heater core. Very tiny leaks in the radiator core may be stopped by a good quality stop leak. After repairing leaks, the system should be rechecked for minor leaks as these will quickly become major

ones. If the radiator hoses swell excessively while testing the system, it indicates the hoses are in a weakened condition and should be replaced.

Hand drops quickly

Indicates that serious leakage is present. Large radiator leaks should be repaired by a reputable radiator repair shop.

#### 10. INTERIOR LEAKAGE

A. WHEN THE GAUGE SHOW A PRESSURE DROP AND THERE IS NO VISIBLE LEAKAGE. Remove the tester and replace the pressure cap. Run the engine to churn up the oil. Shut off the engine. Pull the oil level dipstick and examine it for water globules or light colored foam. Another method would be to remove the crankcase drain plug and drain out a small amount of oil. Water, being the heaviest, should drain out first. Transmission intercoolers are also possible sources of leakage. Check the transmission dipstick for water globules or light foam.

B. Compression or combustion leakage into the cooling system can be detected as follows:

1. With the system and radiator pressure cap cool, carefully remove the pressure cap and apply the tester to the filler neck.
2. Let the engine idle and warm up to normal operating temperature. WATCH CAREFULLY - IF THE GAUGE INDICATES PRESSURE IS BUILDING UP FAST, RELEASE THE PRESSURE BY TURNING OFF THE ENGINE AND ROTATING THE PRESSURE VALVE RELEASE HANDLE ON THE TESTER HEAD CLOCKWISE UNTIL IT IS

PARALLEL TO THE TESTER HEAD HANDLE. (See step 11 below) Since this tester is not designed to release pressure below 30 p.s.i., do not allow the pressure to build up past the arrow indicating the maximum for each system. When pressure builds up fast, a leak exists as a result of a blown gasket. Replace the head gasket.

3. If pressure does not build up immediately, then operate the tester pump until the gauge reads within the range for the system being tested. If the gauge hand vibrates, this indicates a compression or combustion leak into the cooling system. Location of a compression leak is determined by disconnecting one spark plug at a time. (Refer to ignition system guidelines for the proper procedure. Some systems will be damaged if this test is performed improperly.) The gauge hand will stop or decrease vibrating when the spark plug of the leaking cylinder is shorted out. Retest the system after repairing the leak.

## 11. REMOVE THE TESTER FROM THE RADIATOR NECK

Release pressure in the cooling system by rotating the pressure valve release handle on top of the tester head clockwise until it is parallel to the tester head handle. In this position the pressure valve is compressed, releasing the pressure in the system. Wait until all pressure is released before removing the tester head from the filler neck.

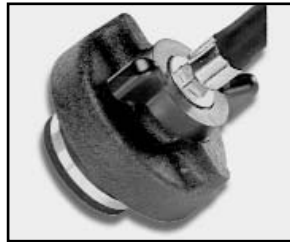

*Tester head with pressure valve released.*

## TESTER ADAPTERS

### Truck adapter kit (For testing 2<sup>11</sup>/<sub>16</sub>" O.D., <sup>3</sup>/<sub>4</sub>" deep "B" size filler necks and caps)

To test the pressure cap, apply cap to the wide end of the cap adapter, attach opposite end of the cap adapter to the Pressure Tester head by pressing together and rotating the adapter clockwise until the tester locking ears contact the stops on the adapter cams.



To test the cooling system, insert the <sup>7</sup>/<sub>8</sub>" thick rubber plug into radiator filler neck. Apply the large end of the system adapter to the filler neck by pressing and rotating the adapter until the locking ears contact the stops on the filler neck. Install the Pressure Tester head to the top of the adapter in the manner described in step 7 of "testing the cooling system" on page 5 in this book.

---

### GM 4 Cylinder System Testing Adapter

Install the rubber gasket inside the large "B" size well of the radiator filler neck adapter. Attach the radiator filler neck adapter, with the rubber gasket inside, to the filler neck on the top of the external thermostat housing by pressing and rotating the adapter clockwise until the locking ears contact the stops on the filler neck. Install the Pressure Tester head to the top of the adapter in the manner described in step 7 of "testing the cooling system" on page 5 in this book.



---

### "A" size Cap Testing Adapter (For testing 2<sup>1</sup>/<sub>8</sub>" O.D., <sup>3</sup>/<sub>4</sub>" deep "A" size pressure caps)

Attach pressure cap to be tested to the bottom of the cap adapter by pressing and rotating the cap clockwise until the ears on the cap contact the stops on the cap adapter. When testing the lever type pressure caps, make sure lever is up when installing cap. After cap is installed, put lever down for testing. Install the Pressure Tester head to the top of the adapter in the manner described in step 7 of "testing the cooling system" on page 5 of this book.



**White/GMC System Testing Adapter (For testing 2 1/2" threaded diameter)**

Install the threaded end of the adapter onto the radiator filler neck turning clockwise until the adapter gasket creates a seal between itself and the top of the filler neck. Install the Pressure Tester head to the top of the adapter in the manner described in step 7 of 'testing the cooling system' on page 5 of this book.



**Audi / Volkswagen System Testing Adapter (Thread specifications M 48 x 3)**

Install the threaded end of the adapter onto the radiator or reservoir filler neck turning clockwise until the adapter gasket creates a seal between itself and the top of the filler neck. Install the Pressure Tester head to the top of the adapter in the manner described in step 7 of 'testing the cooling system' on page 5 of this book.



**Audi / Volkswagen Cap Testing Adapter (Thread specifications M 48 x 3)**

Thread either end of the Audi/ Volkswagen Cap adapter into the Audi/Volkswagen System adapter until a seal is created between the two adapters. Install the Pressure Tester head to the top of the adapter in the manner described in step 7 of 'testing the cooling system' on page 5 of this book. Thread the pressure cap to be tested onto the exposed end of the cap adapter clockwise until a seal is created between the gasket of the cap and the end of the cap adapter.



**Volvo / Saab / Renault Threaded System Testing Adapter (Thread specifications M 43.2 x 3)**

Install the threaded end of the adapter onto the radiator or reservoir filler neck turning clockwise until the adapter gasket creates a seal between itself and the top of the filler neck. Install the Pressure Tester head to the top of the adapter in the manner described in step 7 of 'testing the cooling system' on page 5 of this book.



**BMW Threaded System Testing Adapter (Thread specifications M 52 x 3)**

Install the threaded end of the adapter onto the radiator or reservoir filler neck turning clockwise until the adapter gasket creates a seal between itself and the top of the filler neck. Install the Pressure Tester head to the top of the adapter in the manner described in step 7 of 'testing the cooling system' on page 5 of this book.



**Mini Cap Testing Adapter (Fits 45mm O.D. caps)**

Install the radiator cap to be tested to the small diameter end of the adapter by pressing down and rotating clockwise. Attach the larger diameter end of the cap adapter to the Pressure Tester head to the top of the adapter in the manner described in step 7 of 'testing the cooling system' on page 5 of this book.



**Mini Cap System Testing Adapter (Fits 32mm I.D., 16 mm deep filler necks)**

Attach the small end of the system adapter to the radiator filler neck by pressing down and rotating clockwise until the locking ears on the adapter contact the stops on the filler neck. Install the Pressure Tester head to the top of the adapter in the manner described in step 7 of 'testing the cooling system' on page 5 of this book.



**LeMans / Jaguar / Range Rover System Testing Adapter (Thread specifications M 52 x 3)**

Install the threaded end of the adapter onto the radiator or reservoir filler neck turning clockwise until the adapter gasket creates a seal between itself and the top of the filler neck. Install the Pressure Tester head to the top of the adapter in the manner described in step 7 of 'testing the cooling system' on page 5 of this book.



### Micro Cap Testing Adapter (Fits 44mm O.D. caps)

Install the radiator cap to be tested to the small diameter end of the adapter by pressing down and rotating clockwise. Attach the larger diameter end of the cap adapter to the Pressure Tester head to the top of the adapter in the manner described in step 7 of "testing the cooling system" on page 5 of this book.



### Micro Cap System Testing Adapter (Fits 31mm I.D., 10 mm deep filler necks)

Attach the small end of the system adapter to the radiator filler neck by pressing down and rotating clockwise until the locking ears on the adapter contact the stops on the filler neck. Install the Pressure Tester head to the top of the adapter in the manner described in step 7 of "testing the cooling system" on page 5 of this book.



### Ford / GM / Saturn Threaded System Testing Adapter (Thread specifications M 52 x 2.5)

Install the threaded end of the adapter onto the radiator or reservoir filler neck turning clockwise until the adapter gasket creates a seal between itself and the top of the filler neck. Install the Pressure Tester head to the top of the adapter in the manner described in step 7 of "testing the cooling system" on page 5 of this book.



### Ford / GM / Saturn Threaded Cap Testing Adapter

Install the radiator cap to be tested to the threaded end of the adapter. Attach the larger diameter end of the cap adapter to the Pressure Tester head to the top of the adapter in the manner described in step 7 of "testing the cooling system" on page 5 of this book.



### Volkswagen System Testing Adapter

Install the threaded end of the adapter onto the radiator or reservoir filler neck turning clockwise until the adapter gasket creates a seal between itself and the top of the filler neck. Install the Pressure Tester head to the top of the adapter in the manner described in step 7 of 'testing the cooling system' on page 5 of this book.



### BMW Threaded system testing adapter

Install the threaded end of the adapter onto the radiator or reservoir filler neck turning clockwise until the adapter gasket creates a seal between itself and the top of the filler neck. Install the Pressure Tester head to the top of the adapter in the manner described in step 7 of 'testing the cooling system' on page 5 of this book.



### GM System Testing Adapter

Install the threaded end of the adapter onto the radiator or reservoir filler neck turning clockwise until the adapter gasket creates a seal between itself and the top of the filler neck. Install the Pressure Tester head to the top of the adapter in the manner described in step 7 of 'testing the cooling system' on page 5 of this book.



### GM Cap Testing Adapter (Fits 48mm O.D. caps)

Install the threaded end of the adapter onto the radiator or reservoir filler neck turning clockwise until the adapter gasket creates a seal between itself and the top of the filler neck. Install the Pressure Tester head to the top of the adapter in the manner described in step 7 of 'testing the cooling system' on page 5 of this book.



**GM Cap Testing Adapter (Fits 48mm O.D. caps)**

Install the radiator cap to be tested to the threaded end of the adapter. Attach the larger diameter end of the cap adapter to the Pressure Tester head to the top of the adapter in the manner described in step 7 of 'testing the cooling system' on page 5 of this book.



**Ford / Mercury System Testing Adapter**

Install the threaded end of the adapter onto the radiator or reservoir filler neck turning clockwise until the adapter gasket creates a seal between itself and the top of the filler neck. Install the Pressure Tester head to the top of the adapter in the manner described in step 7 of 'testing the cooling system' on page 5 of this book.



**Ford / Mercury Cap Testing Adapter**

Install the radiator cap to be tested to the threaded end of the adapter. Attach the larger diameter end of the cap adapter to the Pressure Tester head to the top of the adapter in the manner described in step 7 of 'testing the cooling system' on page 5 of this book.



**Audi / Volkswagen System Testing Adapter**

Install the threaded end of the adapter onto the radiator or reservoir filler neck turning clockwise until the adapter gasket creates a seal between itself and the top of the filler neck. Install the Pressure Tester head to the top of the adapter in the manner described in step 7 of 'testing the cooling system' on page 5 of this book.



**Audi / Volkswaten Cap Testing Adapter**

Install the radiator cap to be tested to the threaded end of the adapter. Attach the larger diameter end of the cap adapter to the Pressure Tester head to the top of the adapter in the manner described in step 7 of 'testing the cooling system' on page 5 of this book.



**Mercedes System Testing Adapter**

Install the threaded end of the adapter onto the radiator or reservoir filler neck turning clockwise until the adapter gasket creates a seal between itself and the top of the filler neck. Install the Pressure Tester head to the top of the adapter in the manner described in step 7 of 'testing the cooling system' on page 5 of this book.



**Ford / Mercury / Mazda SUV's System Testing Adapter**

Install the threaded end of the adapter onto the radiator or reservoir filler neck turning clockwise until the adapter gasket creates a seal between itself and the top of the filler neck. Install the Pressure Tester head to the top of the adapter in the manner described in step 7 of 'testing the cooling system' on page 5 of this book.



**Ford / Mercury / Mazda SUV's Cap Testing Adapter**

Install the radiator cap to be tested to the threaded end of the adapter. Attach the larger diameter end of the cap adapter to the Pressure Tester head to the top of the adapter in the manner described in step 7 of 'testing the cooling system' on page 5 of this book.



**Volvo Medium and Heavy Duty System Testing Adapter**

Install the threaded end of the adapter onto the radiator or reservoir filler neck turning clockwise until the adapter gasket creates a seal between itself and the top of the filler neck. Install the Pressure Tester head to the top of the adapter in the manner described in step 7 of 'testing the cooling system' on page 5 of this book.



### TESTER REPAIR PARTS, GASKETS AND SEALS

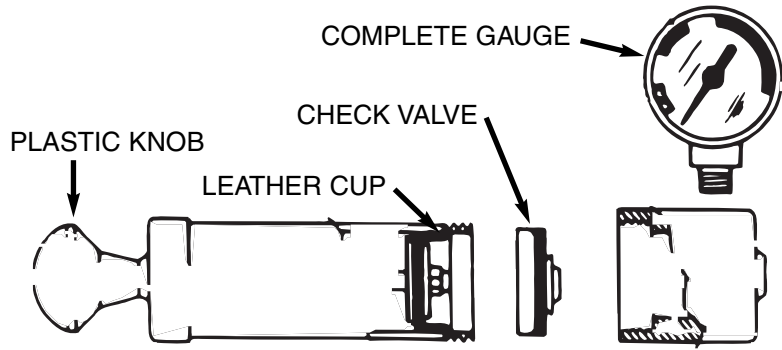

**Conversion Kit**

For renewing the 30-Pound tester or converting the 18-pound tester to the 30-pound design. Includes a 30-pound gauge, hose and head, and instruction manual. Use any good thread sealing compound while installing gauge and hose. Tighten securely.



**Hose and Head Kit**

For use with 18 or 30 pound testers. Includes spacer washer for 1" deep filler necks.



**Head attachment repair kit**

includes rubber spacer. Use this kit with the 30-pound tester only. Head attachment repair kit for older 18-pound testers still available.



**2" x 7/8" rubber plug**  
for truck cooling system; can be ordered for replacement separately from the truck adapter kit.



**1<sup>9</sup>/<sub>16</sub>" x 1/4" rubber spacer**

Drop in 1" deep filler necks for testing.



**2<sup>11</sup>/<sub>16</sub>" x 3/16" rubber gasket**  
for use with the GM 4 cyl. adapter kit when checking late model GM X-cars with the 2.5L engine and J-cars with the 1.8L and 2.0L engines. This gasket is available for replacement or for those already owning a truck adapter kit.

## CARE OF THE PRESSURE TESTER

This is an accurate instrument - treat it as such. Its usefulness depends on its accuracy; therefore, do not drop it or use it roughly.

With reasonable care this instrument will give years of dependable service.

Three or four drops of light oil in the pump air inlet occasionally, to keep leather piston flexible, is all that is necessary. Keep the tester and adapters in their carrying cases when not in use.

Radiator Cap Pressure Ranges	
4 p.s.i. Cap.....	3-5 Lbs.
7 p.s.i. Cap.....	6-8 Lbs.
10 p.s.i. Cap .....	9-11 Lbs.
13 or 14 p.s.i. Cap .....	12-16 Lbs.
15 or 16 p.s.i. Cap .....	14-18 Lbs.
18 p.s.i. Cap.....	16-20 Lbs.
20 p.s.i. Cap .....	18-22 Lbs.
30 p.s.i. Cap .....	28-30 Lbs.

## REPAIRING THE TESTER

### CHECK VALVE

1. Unscrew the pump tube from the tester body. The end cap is pressed on to the tube permanently; do not attempt to remove it.
2. Lift the check valve and gasket out of the tester body. If it requires cleaning, clean it carefully and replace it.
3. If the check valve or gasket is worn or damaged, a replacement valve is available.
4. After dropping check valve unit into proper position, screw the pump tube in place tightly by hand.

### FLEXIBLE HOSE

A damaged or worn flexible hose may be replaced with a Wetherhead #81430-14" Universal Oil Filter Line and #48x4 SAE male connector. Use any good thread sealing compound and tighten securely. Repair parts may be ordered through your supplier. See the part number crossover list in the back of this book.

PRESSURE RELEASE LEVEL  
CONVERSION CHART

POUNDS	kPa	BAR	MILLIBAR
1	6.89	0.06	6.8
2	13.78	0.13	13.7
3	20.68	0.20	20.6
4	27.57	0.27	27.5
5	34.47	0.34	34.4
6	41.36	0.41	41.3
7	48.25	0.48	48.2
8	55.15	0.55	55.1
9	62.04	0.62	62.0
10	68.94	0.68	68.9
11	75.83	0.75	75.7
12	82.72	0.82	82.6
13	89.62	0.89	89.5
14	96.51	0.96	96.4
15	103.41	1.03	103.3
16	110.30	1.10	110.2
17	117.19	1.17	117.1
18	124.09	1.24	124.0
19	130.98	1.30	130.9
20	137.88	1.37	137.8
21	144.77	1.44	144.6
22	151.66	1.51	151.5
23	158.56	1.58	158.4
24	165.45	1.65	165.3
25	172.35	1.72	172.2
26	179.24	1.79	179.1
27	186.13	1.86	186.0
28	193.03	1.95	195.4
29	199.92	1.99	199.8
30	206.82	2.06	206.7

## TESTER WARRANTY

Stant Manufacturing Inc. ("Stant") warrants its Testers to be free from defects in material and workmanship for a period of one year from the date of sale to the end user. This Limited Warranty is subject to the following conditions and exclusions:

1. This Limited Warranty is void if the Testers have been subjected to abuse, accident (including misuse), inadequate maintenance, alteration or any other cause not a result of a defect in material and/or workmanship.
2. This Limited Warranty does not cover usable and replaceable parts and any other parts that must be replenished with normal use.
3. This Limited Warranty covers only the replacement of a Tester within the 1 year warranty period. This warranty shall be fulfilled only by replacement of the tester at the option of Stant.
4. For Warranty service, contact Stant Customer Service at 800-822-3121 extension 330. Please have your model number, serial number and purchase date information with you when you call. **Do not return the tester unit to Stant for service.** If your tester warranty claim is valid, Stant will ship you a new unit at no charge. Applicable shipping and handling charges will apply. **For your warranty claim to be valid, you must return the warranty registration card.**
5. This Limited Warranty applies only to Testers owned and operated within the United States and Canada.
6. This Limited Warranty extends only to the original end user and is assignable or transferable only upon written authorization by Stant.
7. THIS LIMITED WARRANTY IS EXPRESSLY IN LIEU OF ANY EXPRESSED OR IMPLIED WARRANTIES, INCLUDING ANY IMPLIED WARRANTY OF MERCHANTABILITY OR FITNESS FOR ANY PURPOSE AND OF ANY OTHER OBLIGATION ON THE PART OF STANT. UNDER NO CIRCUMSTANCES SHALL STANT BE LIABLE FOR INCIDENTAL OR CONSEQUENTIAL DAMAGES.

Some states do not allow the exclusion or limitation of incidental or consequential damages, therefore the above exclusion may not apply to a particular purchaser. This limited warranty gives you specific legal rights, and purchasers may also have other rights which vary from state to state.

Stant reserves the right to make changes in the design and/or improvements to its products, including the Testers, without any obligation to include these changes in any products previously manufactured and/or sold.

Stant does not authorize any warranty other than that contained herein nor does it authorize any person or persons to assume for it any obligations or liability except as stated herein.

**Stant Corporation**  
**Connersville, Indiana 47331-1696**

JB-1164 (Rev. 7/09) Printed in U.S.A.